

# **AUTOMATIC MECHANISM TO CLEAN THE SOLDER TIP OF THE SOLDER IRON**

W. K. A. U. K. Fernando\*, K. P. Vidanapathirana

*Department of Electronics, Wayamba University of Sri Lanka, Kuliyaipitiya, Sri Lanka*  
*upekshaforyou@gmail.com\**

## **ABSTRACT**

This paper reports on a real time solution for the problem caused by the oxidization of solder iron tip of an automatic selective soldering and optical inspection machine. DC motor with gear wheel mechanism was used for the movement of the system. The system consists of two cup brushes, when one cup brush rotates clockwise at the same time, the other rotates anticlockwise and the impurities automatically removed from the solder iron tip due to the rotation of the wool cup brushes. These processes were automated using PIC18F4550 microcontroller. Thus the system cleans the solder iron tip automatically avoiding the lead impurities flow in to the working environment and there by providing good solution to the problem. This system was well matched with the company environment, occupational health, safety and quality policies. It can be established at a cost effective and efficient manner and thereby increase the quality soldering process.

**Keywords:** Selective Soldering, Solder Iron Tip, DC motor, Microcontroller

## **1. INTRODUCTION**

Solder irons are used in the production lines for soldering purpose. After soldering more than once, residual flux particles collected on solder iron tip. Hence the heat transfer is not sufficient for the new joint to be soldered. As a result of this, quality of the soldering process is degraded in terms of applying solder on solder pad or accumulating solder on top of the solder iron tip. This is a very serious issue in a system operating in a high-end production line.

Moreover, the common practice of cleaning the solder iron tip is by applying solder tip activator, brush on metal wool and wipe with wet sponge. Solder iron tip carried by automatic robotic arm specially require an automatic cleaning system. Most of the selective soldering machines use a nitrogen blower to reduce the effect of oxygen. But it is not completely practical method and not a very accurate cleaning mechanism. So accurate and efficiency of the mechanism has to be enhanced. Also there should be a less time consuming and cost effective

technique to clean the solder tip. By considering these drawbacks and the improvements, this automatic solder tip cleaning system was implemented.

It was identified that lead dust and fumes releases during the soldering process. Lead impurities and fumes not only harm human but also to the machines. Equipments that are used in the automatic selective soldering machine like optical inspection camera can easily get damaged when exposed to the dust. This is one of the main reasons for heat production in the equipment. When large amount of heat is produced equipment may wear out before its actual life period ends. The proposed automatic soldering iron tip cleaner can be used in the production line to avoid all above problems.

## 2. EXPERIMENTAL

### 2.1. Methodology

The real time automated solder iron tip cleaner is used to clean the solder iron tip automatically and to collect the residual flux particles accumulated on the solder iron tip during continuous soldering process. The system developed consists of a wire cup brush which brushes the iron tip.

A DC gear motor was used to rotate the cup brush that is wound with the cleaning materials. This material was used to clean the solder iron tip and get hold of the impurities after cleaning. The entire apparatus was placed parallel to the automatic selective soldering machine at one end. The robotic arm is placed on middle of the two cup brushes, when it needs to clean. The microcontroller PIC18F4550 was used to automate the entire process.

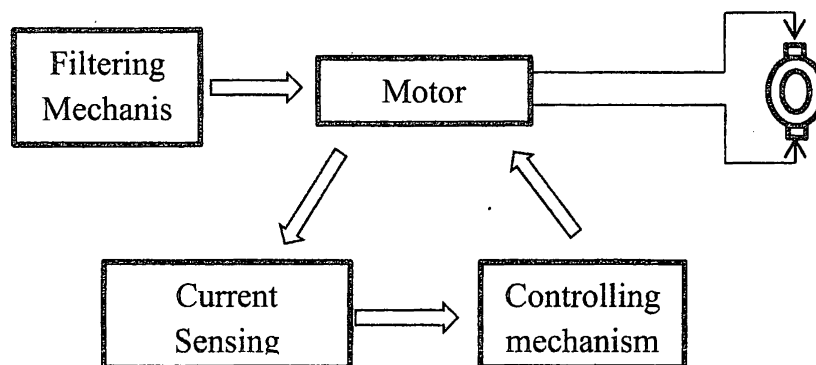

Figure 1: Block diagram of circuit design

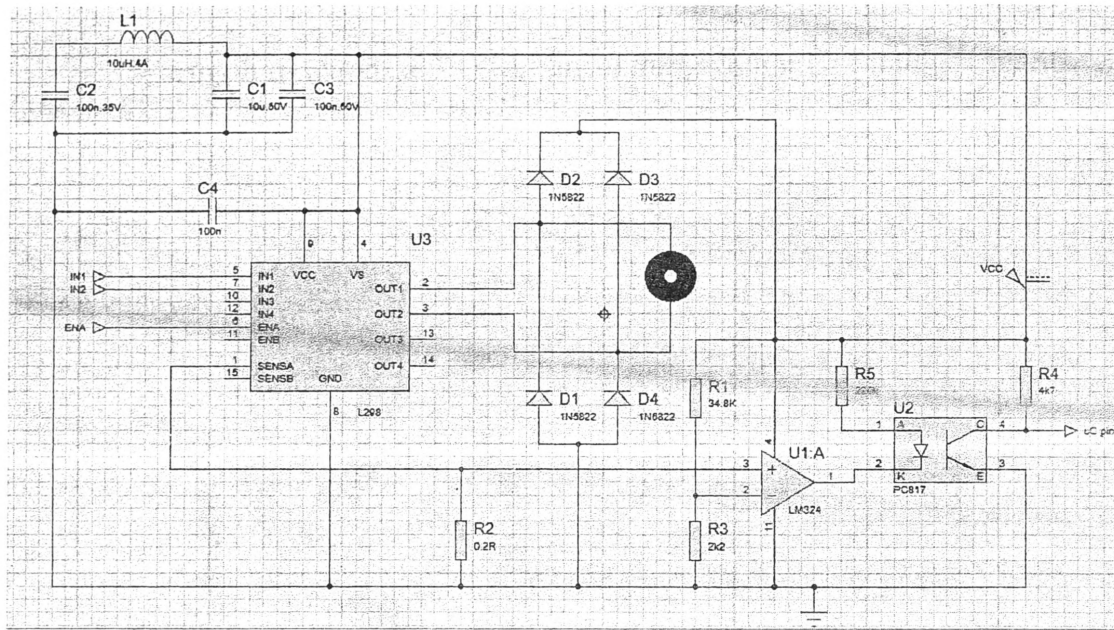

Figure 2: Circuit diagram of the system

## 2.2. Components and Circuit

### 2.2.1. L298 Dual full Bridge Driver

L298 is an integrated monolithic, high voltage, high current dual full bridge driver designed to accept standard logic levels and drives inductive loads such as relays, solenoids and DC motors. Two enable inputs are provided to enable or disable the device independent of the input signal. The emitters of the lower transistors of each bridge were connected together and the corresponding external terminal can be used for the connection of an external sensing resistors. Following Figure 3, shows the internal block diagram of the L298 dual full bridge motor driver.

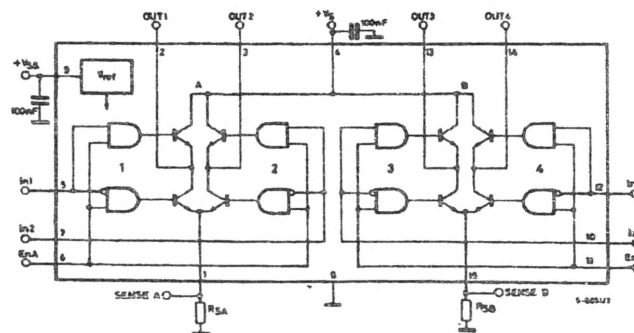

Figure 3: Internal block diagram of the L298 dual bridge motor driver

This dual full bridge motor driver; operate up to 46 V supply voltage and total DC current up to 4 A.<sup>1</sup>

### 2.2.2. LM317 Adjustable Regulator

The voltage regulator circuit diagram using LM317 is shown in Figure 4.

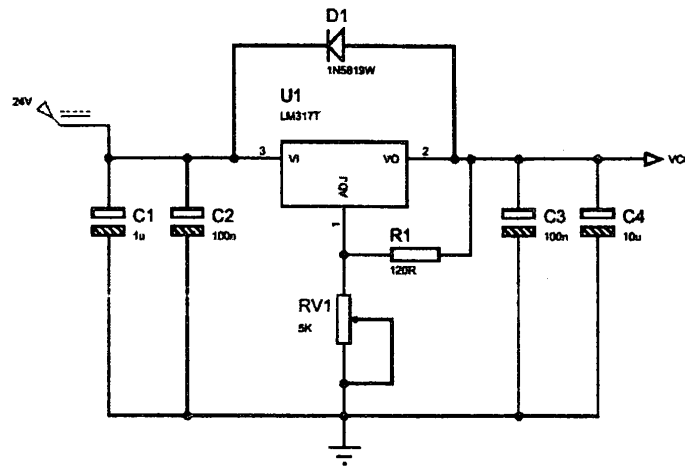

Figure 4: Voltage regulator Circuit

### 2.2.3. LM324 Single Supply Quad Op Amp

The LM324 is a low cost quad operational amplifier with true differential inputs. It has several distinct advantages over standard operational amplifier types in single supply applications. The quad amplifier can operate at supply voltage as low as 3 V or as high as 32 V<sup>2</sup>.

The current sensing control circuit diagram using LM324 is shown in Figure 5.

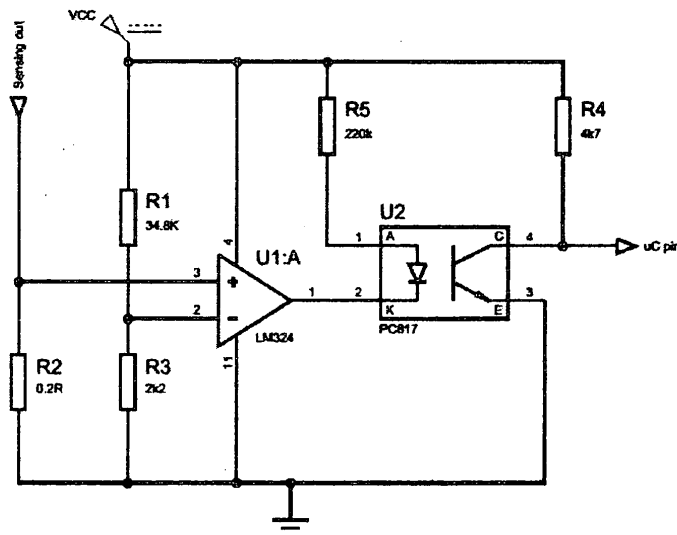

Figure 5: Current Sensing Circuit

## 3. RESULTS AND DISCUSSION

The experimental set up of the proposed system is shown in the Figure 6 and Figure 7. They illustrate the prototype of the automatic cleaning mechanism to clean the solder tip of the solder iron.



Figure 6: Motor driving system

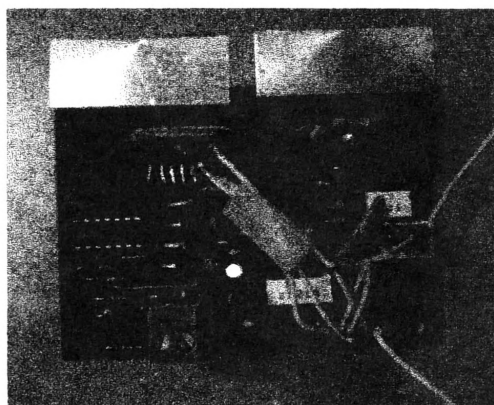

Figure 7: Circuit of the system

### Advantages of the Proposed System

There are lots of advantages of using the automatic solder tip cleaner for selective soldering machine. Some of them are,

- Can obtain high quality PCB products
- Low cost cleaning mechanism
- Easy to operate and quick cleaning method
- Less time consuming and motor can be driven in two directions
- Motor current is continuously monitored and cutoff at excessive current consumption

### 3.1. Limitations of the Proposed System

- RPM of the motor which is connected to the wire brush is a major limitation of this system. Lead impurity might spray on to the PCB board when the motor is rotating in excessive RPM values
- Soldering iron placement is another limitation of this system. It should be placed through the two wire brushers according to the correct position, if not automatic cleaning machine will not support to the exact cleaning process.

#### **4. CONCLUSION**

The automatic solder iron tip cleaning mechanism has been successfully designed and fabricated. This project has been planned in cost effective manner to obtain high efficiency and reliability. This system is time saving solution and it will support to obtain high quality products.

#### **ACKNOWLEDGEMENTS**

Authors would like to express their indebt gratitude to the staff of the Department of Electronics, Faculty of Applied Sciences, Wayamba University of Sri Lanka and that of Test Engineering Department of Variosystems (Pvt) Ltd Badalgama.

#### **REFERENCES**

- [1]. Datasheet of L298 Dual Full- Bridge Driver
- [2]. Datasheet of LM324 Single supply quad Operational Amplifiers