

EMBEDDED MICROCONTROLLERS WHERE THE ELECTRICIAN MEETS THE PROGRAMMER

R.J.K.U. Niroshan Ranatunga

Department of Electronics, Faculty of Applied Sciences, Wayamba University of Sri Lanka, Kuliypitiya

Are we found Microcontrollers in our day-to-day life?

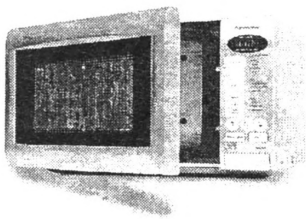

Yes, Microcontrollers are hidden inside a surprising number of products these days. If your microwave oven has an LED or LCD screen and a keypad, it contains a microcontroller. All modern automobiles contain at least one microcontroller, and can have as many as six or seven: The engine is controlled by a microcontroller, as are the anti-lock brakes, the cruise control and so on. Any device that has a remote control almost certainly contains a microcontroller: TVs, VCRs and high-end stereo systems all fall into this category. Nice SLR and digital cameras, cell phones, camcorders, answering machines, laser printers, telephones (the ones with caller ID, 20-number memory, etc.), pagers, and feature-laden refrigerators, dishwashers, washers and dryers (the ones with displays and keypads)... You get the idea. Basically, any product or device that interacts with its user has a microcontroller buried inside. Also microcontrollers play major role in Robotics.

What is a Microcontroller?

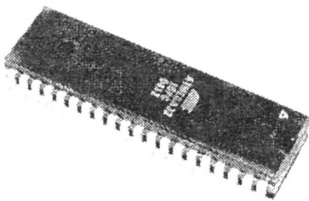

Microcontroller is a Single chip computer. While the desktop computer you are using is a "general purpose computer" that can run any of thousands of programs. Microcontrollers are "special purpose computers." Microcontrollers do one thing well. There are a number of other common characteristics that define microcontrollers.

- Microcontrollers are embedded inside some other device.
- They are dedicated to one task and run one specific program.
- The program is stored in ROM (read-only memory) and generally does not change.
- They are often low-power devices. A desktop computer is almost always plugged into a wall Socket and might consume 50 watts of electricity. A battery-operated microcontroller might consume 50 milliwatts.
- A microcontroller has a dedicated input device and often (but not always) has a small LED or LCD display for output. A microcontroller also takes input from the device it is controlling and controls the device by sending signals to different components in the device.
- A microcontroller is often small and low cost.
- Some of special microcontrollers have wide operating temperature range for heavy usage.

History of Microcontrollers



The first single chip microprocessor was the 4 bit Intel 4004 released in 1971, with other more capable processors available over the next several years. These however all required external chip(s) to implement a working system, raising total system cost, and making it impossible to economically computerize appliances.

The first computer system on a chip optimized for control applications - microcontroller was the Intel 8048 released in 1975, with both RAM and ROM on the same chip. This chip went on to be found in over a billion PC keyboards.

Most microcontrollers at this time had two variants. One had an erasable EEPROM program memory, which was significantly more expensive than the PROM variant which was only programmable once.

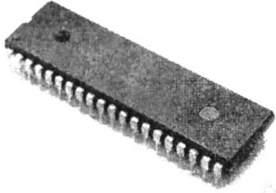

In 1993, the introduction of EEPROM memory allowed microcontrollers (beginning with the Microchip PIC16x84) to be electrically erased quickly without an expensive package as required for EPROM, allowing both rapid prototyping, and In Circuit Serial Programming (ICSP).

The same year, Atmel introduced the first microcontroller using Flash memory. Other companies rapidly followed suit, with both memory types. Cost has plummeted over time. Nowadays microcontrollers are low cost and readily available for hobbyists, with large online communities around certain processors.

Global market for microcontrollers & other chipsets

In this article we'll consider about Microchip PIC16F84A/PIC16F628A microcontroller.

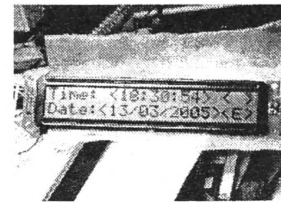
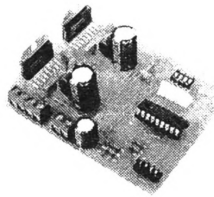

Top ten players in the global chip market

NEC Electronics' merger with Renesas would create the world's No. 3 chipmaker

Global market shares for microcontrollers

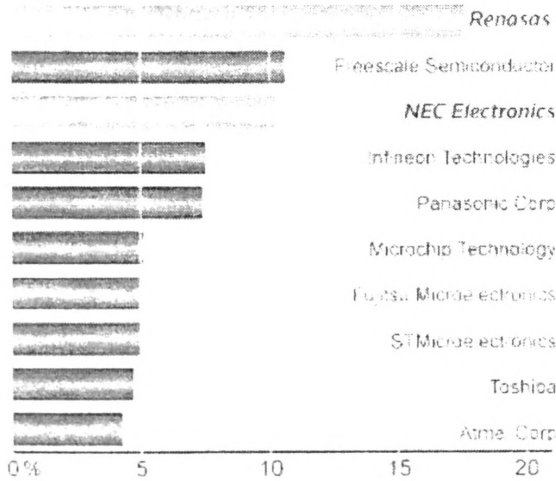

Global chip market share in 2008

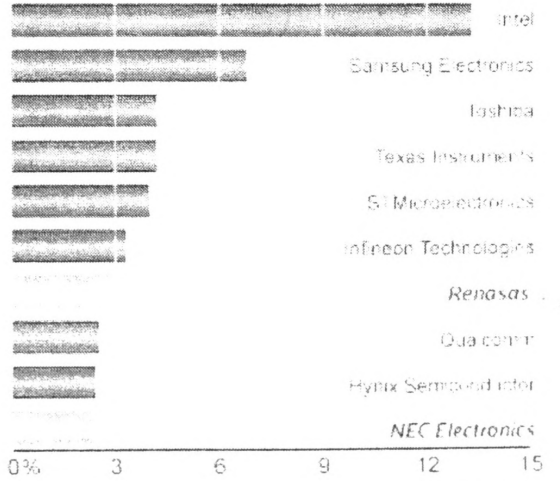

Source: Gartner, 2008

Reuters, Digital Capitalism, 2008

11/03/09

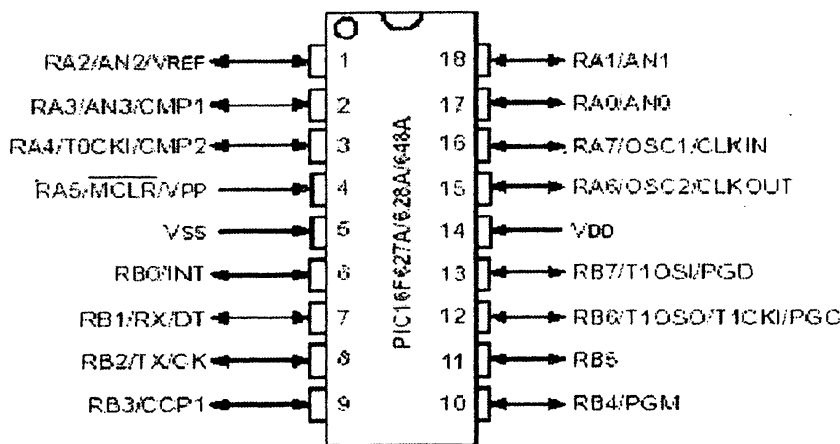
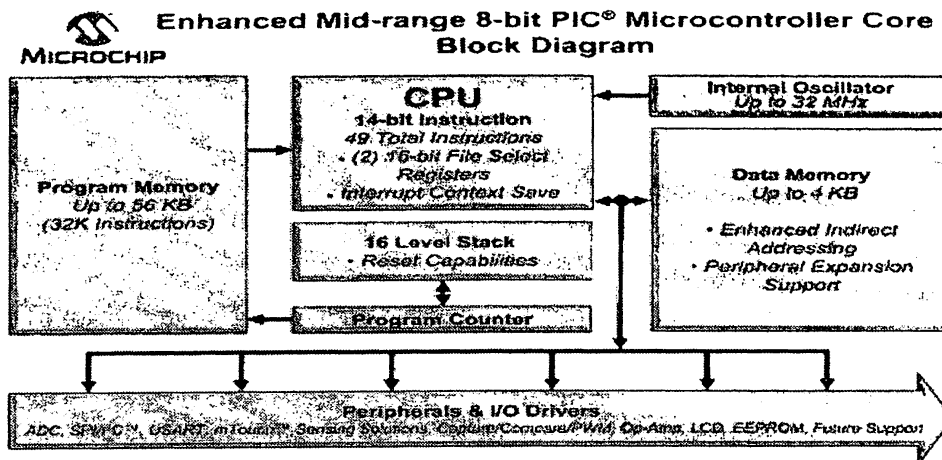

PIC 8 bit microcontroller internal architecture and design

Advantages of getting started with PIC microcontrollers than others

- Relatively low cost for an experiment.
- If you wish to program assembly language (Low level language), as it is a RISC (Reduced Instruction Set Computer) processor it will be very simple to program because you have only 35 instructions to learn.
- Some of PIC16FXXX series available in local radio stores or 1st cross street, Colombo 11.
- Those can be programmed using a RS-232 communication port compatible simple burner called JDM programmer. To build a JDM programmer you will only costs less than 100 rupees.
- Logical outputs of PIC can sink/source up to 25mA. So you can directly drive LED indicators without any amplification.

Requirements for PIC programming

- JDM programmer
- MP LAB IDE (can be free download from www.microchip.com)
- IC PROG/WINPIC PIC programmer (can be free download from internet)
- PC with COM port/windows platform
- Download PIC mid range manual and PIC16F84A/628A datasheet from the internet.

JDM Programmer

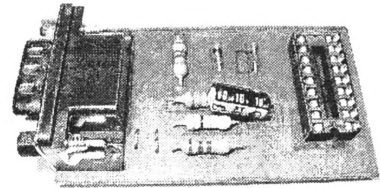
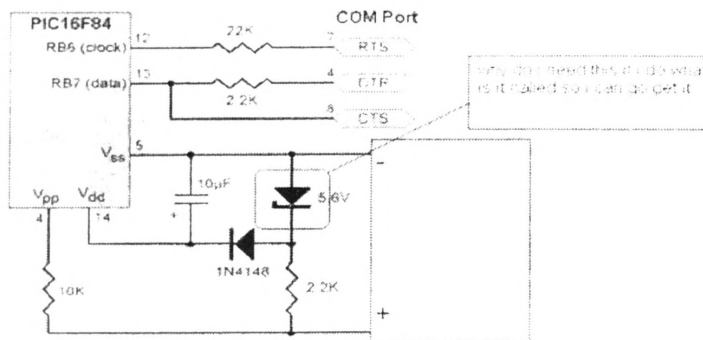

References

- 1). www.microchip.com
- 2). www.rentron.com/pic.htm
- 3). www.hobbyprojects.com/pic_tutorials/introduction_to_pic.html
- 4). www.ic-prog.com
- 5). www.qsl.net/dl4yhf/winpicpr.html
- 6). www.jdm.homepage.dk/newpic.htm